

2 General Specifications

2.1 Specifications and Requirements

2 X 36 – 100 TON PERFECTION LINK SPECIFICATIONS	
Part Number	E70508-1036
Material	Alloy Steel
Load Rating	100 Tons
Weight 2 X 36 – 100 Ton Link	75 lbs. (34.1 kg)
Length	36-inches (914.4 mm)
Link Material Diameter	2-inches (50.8 mm)
Material Hardness	270-302 BHN
Links	Provided in Pairs

2 X 42 – 100 TON PERFECTION LINK SPECIFICATIONS	
Part Number	E70508-1042
Material	Alloy Steel
Load Rating	100 Tons
Weight 2 X 42 – 100 Ton Link	84 lbs. (38.2 kg)
Length	42-inches (1,066.8 mm)
Link Material Diameter	2-inches (50.8 mm)
Material Hardness	270-302 BHN
Links	Provided in Pairs

DRILL COLLAR LIFT BECKET SPECIFICATIONS	
Part Number	E31189 -XXX
Material	Alloy Steel
Load Rating	150 Tons
Weight	234 lbs. (106.4 kg)
Nominal Length	30.4-inches (772.2 mm)
Nominal Width	20-inches (508 mm)
Material Hardness	269-302 BHN

3.2 Drill Collar Lift Becket Wear Table

(All dimensions in inches)

PART NUMBER	BORE CODE	MAX ELEVATOR THRU-BORE C DIA	MAX WEAR "A" @ 150 TONS	MAX WEAR "B" @ 150 TONS
E31189-120-123	120	4.029	-----	4.438
E31189-120-123	121	4.341	-----	4.596
E31189-120-123	122-123	5.406	5.750	-----
E31189-121-123	121-123	5.406	5.750	-----
E31189-122-124	122-124	5.969	6.250	-----
E31189-124	124	5.969	6.250	-----

"C" is the Elevator Thru-Bore.

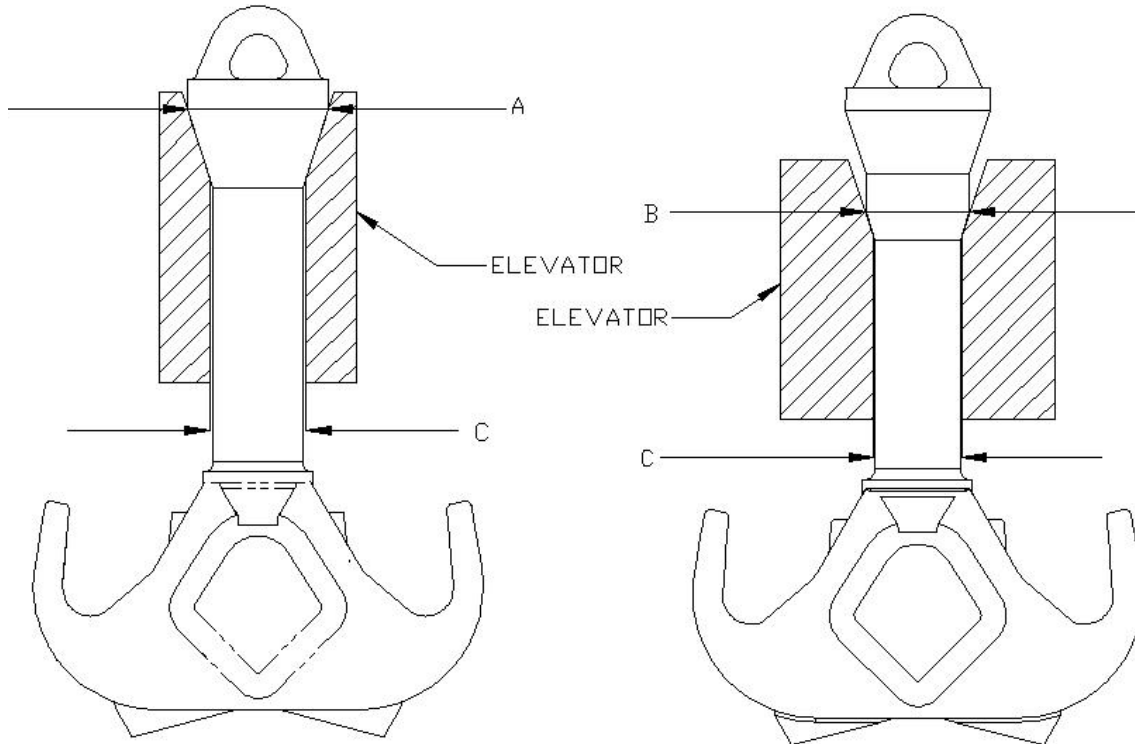

THIS DOCUMENT CONTAINS PROPRIETARY INFORMATION WHICH MAY NOT BE DISCLOSED FOR ANY PURPOSE NOR USED FOR MANUFACTURING PURPOSES WITHOUT WRITTEN PERMISSION FROM FORUM OILFIELD TECHNOLOGIES/ACCESS OIL TOOLS. THIS DOCUMENT IS SUBJECT TO RETURN UPON REQUEST BY FORUM OILFIELD TECHNOLOGIES/ACCESS OIL TOOLS.

REV: DESCRIPTION:		BY:	DATE:	REV:	DESCRIPTION:	BY:	DATE:
0	RELEASED FOR PRODUCTION	SAF	02/09/09				

NOTE:
1. FOR ASSEMBLY

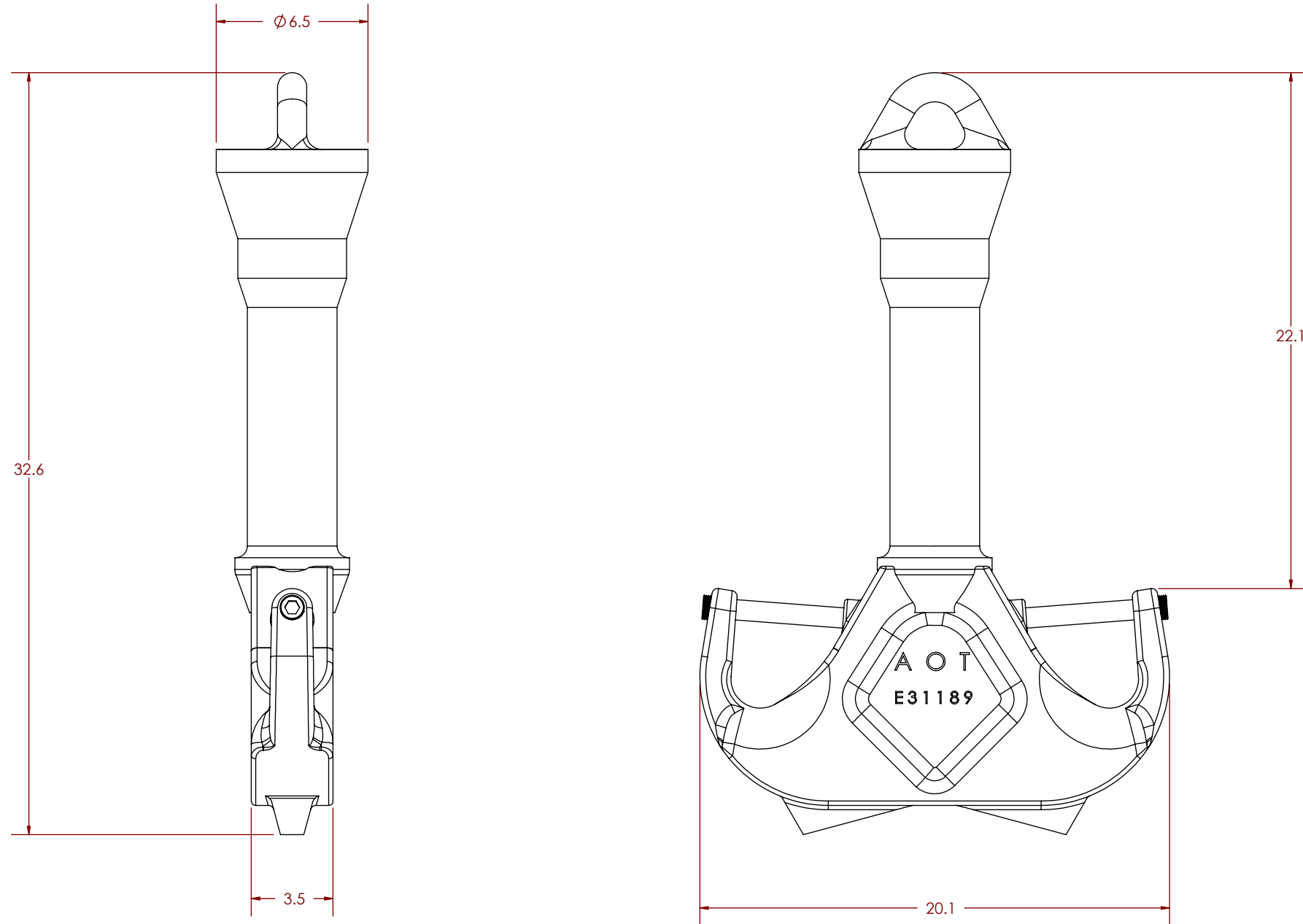

FILENAME: E31189	UNLESS OTHERWISE SPECIFIED DIMENSIONS ARE IN INCHES		APPROVALS		DATE:
TOLERANCES:	DRAWN BY: S. FALCON		02/09/09		
.XXX ± .005"	CHECKED BY:				
.XX ± .02"	APPROVED BY:				
.X ± .1"	REF:				
FRACTIONS ± 1/64"	MATERIAL:				DESC:
ANGLE ± 0°30'	SEE BILL OF MATERIALS				DRILL COLLAR LIFT BECKETT GENERAL ASSEMBLY
HEAT TREAT (IF APPLICABLE):	SCALE 1:12		WT: 28.42 lbs		SIZE: B PART NO: E31189-GA
	SHEET 1 OF 1		REV: 0		

THIS DOCUMENT CONTAINS PROPRIETARY INFORMATION WHICH MAY NOT BE DISCLOSED FOR ANY PURPOSE NOR USED FOR MANUFACTURING PURPOSES WITHOUT WRITTEN PERMISSION FROM FORUM OILFIELD TECHNOLOGIES/ACCESS OIL TOOLS. THIS DOCUMENT IS SUBJECT TO RETURN UPON REQUEST BY FORUM OILFIELD TECHNOLOGIES/ACCESS OIL TOOLS.

REV: DESCRIPTION:		BY:	DATE:	REVISIONS		BY:	DATE:
0	RELEASED FOR PRODUCTION	SAF	02/05/09				

NOTE:
1. FOR GENERAL ASSEMBLY

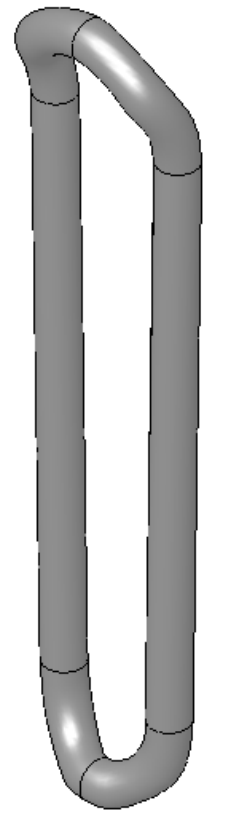
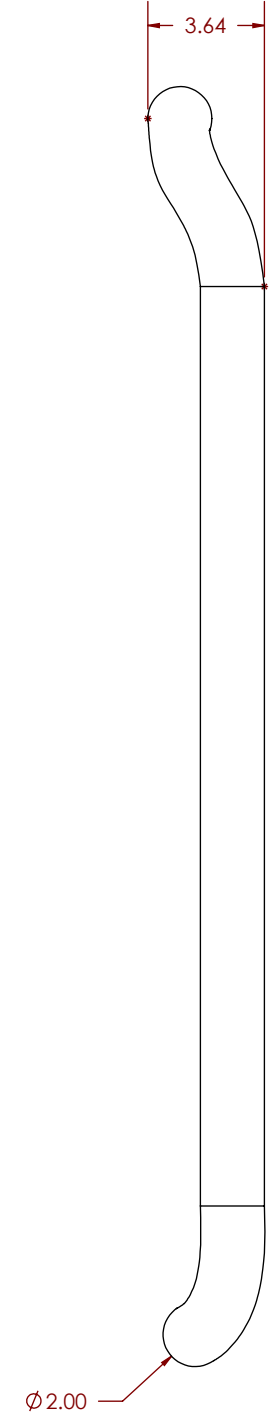
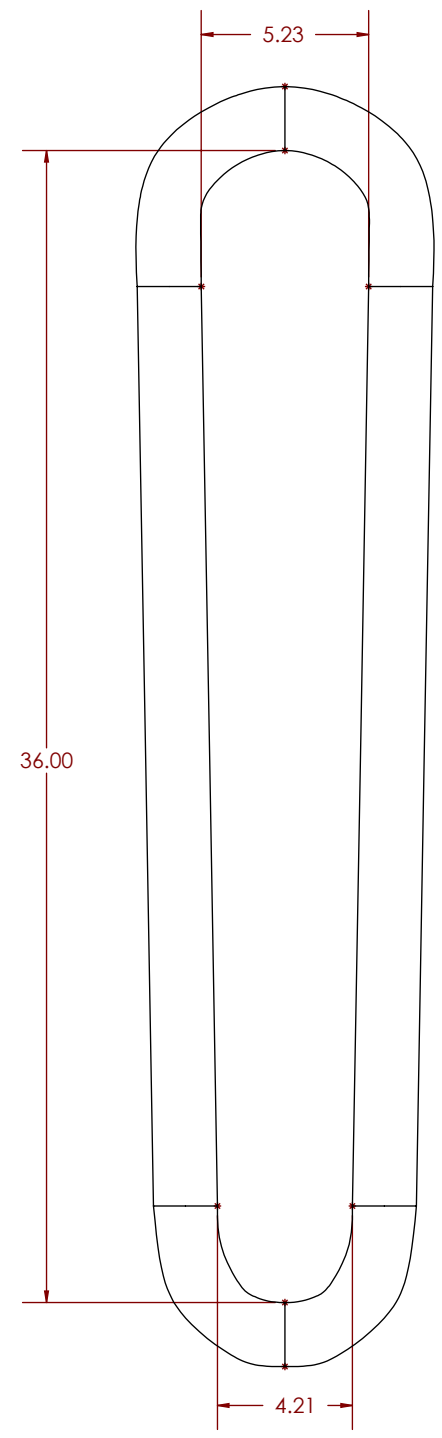

APPROVALS		DATE:	
DRAWN BY:	J. CAILLIER	02/05/09	
CHECKED BY:	S. FALCON	02/05/09	
APPROVED BY:	W. MAST	02/05/09	
REF:	DESC: 2" X 36" BAIL PERFECTION LINKS		
MATERIAL:	GENERAL ASSEMBLY		
HEAT TREAT (IF APPLICABLE):	SIZE: B	PART NO: E70508-1036-GA	REV: 0
N/A	SCALE 1:8	WT: 74.48 lbs	SHEET 1 OF 1