

AOT MRA (150 TON) SQUARE SHOULDER ELEVATOR

AOT #	RANGE	SIZE OF LINKS	WT.
E30158	2 3/8" - 5"	1 3/4" - 2 3/4"	210-185

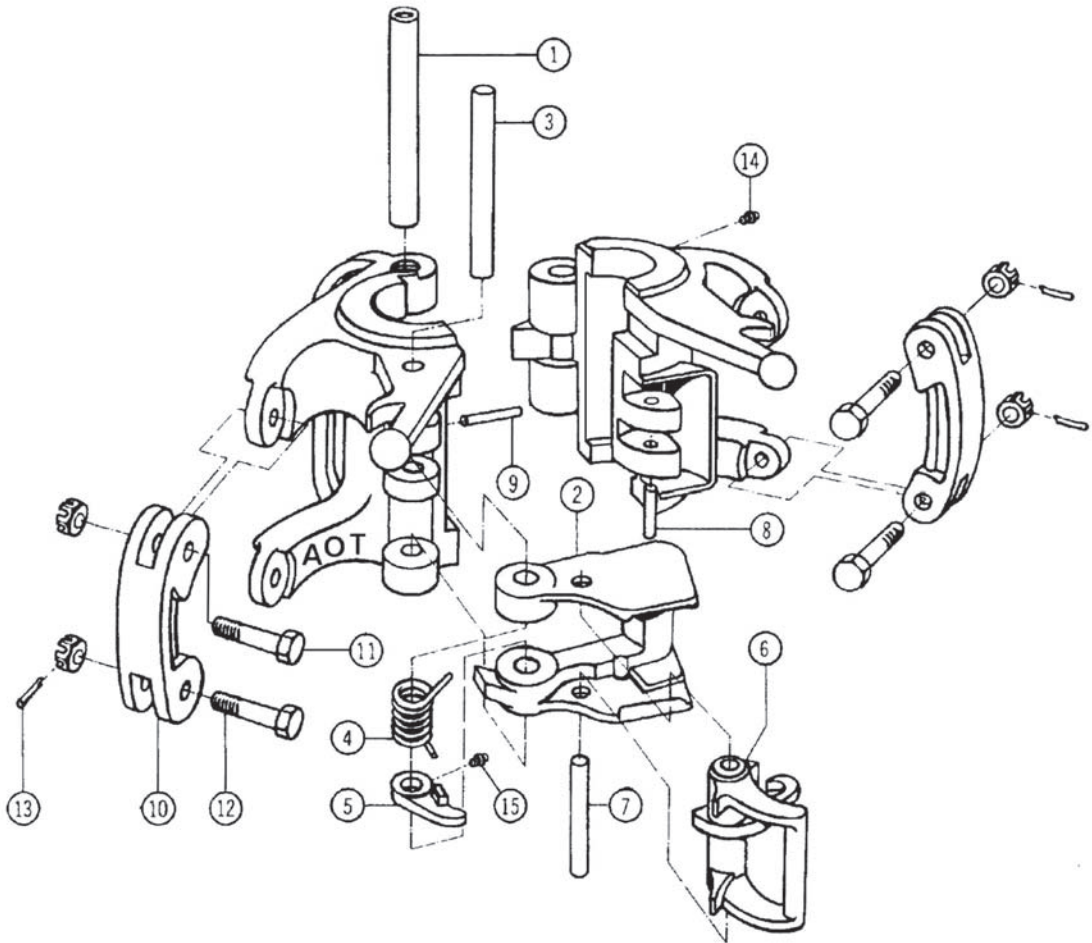

REPLACEMENT PARTS FOR MRA ELEVATORS

AOT #	ITEM #	DESCRIPTION	**SPARES	# REQ.	WT.
E26813	1	HINGE PIN	*	1	4.85
E11763	2	LATCH		1	9.25
E26814	3	LATCH PIN	*	1	.50
E11766	4	LATCH SPRING	2	1	.25
E11581	5	LATCH CAM	1	1	.75
E11764	6	LATCH LOCK	*	1	3.00
E11759	7	LATCH LOCK PIN	1	1	.75
E12529	8	DOOR LUG PIN		1	.25
E8156	9	LATCH PIN RETAINER	1	1	.25
E26817	10	LINK BLOCK		2	3.50
E8031	11	LINK BLOCK PIN		2	.45
E8145-2	12	LINK BLOCK BOLT, & NUT &	2	2	.75
E939672-18	13	COTTER PIN	2	3	.10
E940308-1	14	GREASE FITTING		1	.10
E940308-8	15	GREASE FITTING		1	.10

1 YEAR SPARES, FOR 2 YEARS SPARES ADD 1 EA. OF * THESE ITEMS