

DRILL PIPE & CASING TONGS

Drill Pipe Tongs are the latest addition to the product line of Access Oil Tools and are manufactured at its 42,000 sq. ft. plant located in Broussard, Louisiana

Access was founded in 1985 by professionals with years of experience in oil field sales and manufacturing. We recognized the need for a reliable source of quality equipment to meet the rigorous demands of this industry. Our company has grown steadily over the years and today is a leading supplier of pipe handling equipment to the drilling industry worldwide.

- Licensed under API Spec. Q1, 7K, 8A and 8C
- ISO 9001; 2000 Certified
- All Tongs Pull Tested and Full Certification Available

In addition to the Drill Pipe Tongs detailed in this catalog, Access offers a complete range of manual and proprietary powered handling tools. Manual tools include Elevators, Slips, Safety Clamps, Spiders, Bushings, Casing Scrapers and Stabbing Guides.

The powered tools cover Kelly Spinners, Rotating Mousehole Tool, The "Twister Torque" wrenching tool and the "Twister Spin" which incorporates the Twister Torque tool and a Drill Pipe Spinner.

This detailed parts catalog can be found on the Access web page and can be downloaded in PDF file format.

Web address: www.accessoiltools.com

TORQUE RATINGS

TYPE	TORQUE RATING (ft.lbs.)	SIZE RANGE
C	35,000	2 3/8" - 10 3/4"
B	30,000	13 3/8"
	40,000	9" - 11 3/4"
	55,000	3 1/2" - 9"
B Extended Head (for Casing)	25,000	13 3/8" - 25 1/2"
HT-65	40,000	11 3/4" - 17"
	65,000	3 1/2" - 11 1/4"
HT-100	60,000	16" - 17"
	75,000	12" - 15"
	100,000	4" - 12" and 15 3/4"



AOT TYPE "HT-100" TONG COMPLETE

AOT #	DESCRIPTION	WT.
T200071	TYPE HT-100 TONG COMPLETE LESS LUG JAWS	533.00

NOTE: ADD —ST TO END OF TONG P/N FOR TONG WITH SAFETY HANDLES & SET-BACK HANGER

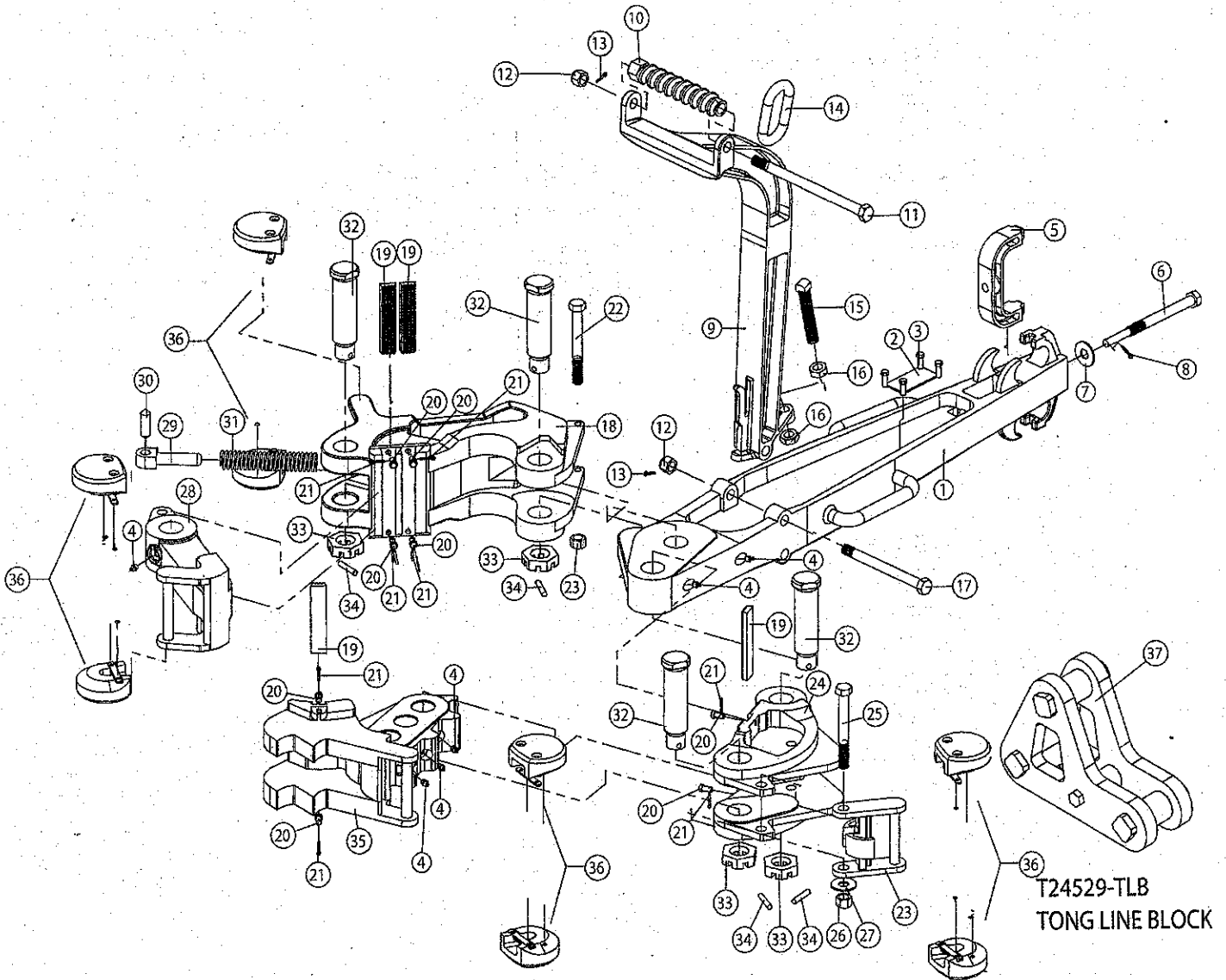

HINGE & LUG JAW ASSEMBLIES FOR TYPE "HT-100" TONG

AOT #	ITEM#	DESCRIPTION	TORQUE RATING	WT.
T200663-1	35	4 - 8 1/2 LUG JAW ASSEMBLY	100,000 ft. lbs.	135.00
T200664	35	8 1/2 — 12 LUG JAW ASSEMBLY	100,000 ft. lbs.	102.00
T200665	35	12 — 15 LUG JAW ASSEMBLY	75,000 ft. lbs.	140.00
T200666	35	15 3/4 LUG JAW ASSEMBLY	100,000 ft. lbs.	162.00
T200667	35	16 — 17 LUG JAW ASSEMBLY	60,000 ft. lbs.	140.00
T200662-1	NP	8 1/2 — 17 HINGEJAW ASSEMBLY	100,000 ft. lbs.	112.00

NOTE: ADD - SH TO END OF LUG JAW PIN FOR JAWS W/SAFETY HANDLES

*Lug & Hinge Jaw Assemblies include Jaw, and any required Tong Dies, Die Retainer Pins, Cotter Pins, & Grease Fittings

** Hinge Jaw Assembly required for sizes greater than 8 1/2

REPLACEMENT PARTS FOR TYPE "HT-100" TONG

AOT #	ITEM #	DESCRIPTION	** SPARES	# REQ.	WT.
T200661-1	1-8	LEVER ASSY. F/TYPE HT-100 TONG		1	191.00
T200661	1	STANDARD LEVER ONLY F/TYPE HT-100 TONG		1	186.00
T200669	2	NAME PLATE		1	.10
T53301-4-3	3	NAME PLATE SCREWS		4	.05
T53201	4	GREASE FITTING		2	.05
T24529	5	TONG LINE RETAINER	1	1	3.65
T24249	6	TONG LINE RETAINER BOLT	1	1	1.08
T50809-N-C	7	WASHER F/RETAINER BOLT	1	1	.05
T51402-8	8	COTTER PIN	1	1	.04
T200668-2	9-16	HANGER ASSY. F/ HT-100 & HT-65 TONG		1	56.00
T200668	9	HANGER ONLY F/ HT-100 & HT-65 TONG		1	47.00
T200668-2-SH	9-16	SET BACK HANGER ASSY. F/ HT-100 & HT-65 TONG		1	64.00
T200668-SH	9	SET BACK HANGER ONLY F/ HT-100 & HT-65 TONG		1	55.00
T12586	10	BALANCING SCREW		1	2.75
T939099-596	11	BALANCING SCREW BOLT		1	2.10
T50512-C	12	BALANCING SCREW BOLT NUT		1	.40
T51402-16	13	COTTER PIN		1	.08
T12863	14	SUSPENSION RING		1	1.50
T939168-133	15	HANGER ADJUSTMENT SCREW		1	.75
T50314-C	16	HANGER JAM NUT		2	.25
T939099-556	17	HANGER BOLT	1	1	1.40
T50512-C	12	HANGER BOLT NUT	1	1	.25
T51402-16	13	COTTER PIN	1	1	.05
T200072-1	18-23	LONG JAW ASSY. F/TYPE HT-100 TONG		1	140.00
T200072	18	LONG JAW F/TYPE HT-100 TONG		1	128.00
T16401-2	19	1/2 X 1 1/4 X 5 TONG DIE	144	AS REQ.	.75
T17194	20	TONG DIE RETAINER PIN	24	AS REQ.	.03
T51402-6	21	COTTER PIN	36	AS REQ.	.01
T50012-52-C8	22	BOLT F/LONG JAW		1	1.75
T50212-C	23	NUT		1	.30
T200074-1	24-27, 19-21	SHORT JAW ASSY. F/TYPE HT-100 TONG		1	87.00
T200074	24	SHORT JAW ONLY F/TYPE HT-100 TONG		1	77.00
T939107-516	25	BOLT		1	.75
T50214-C	26	NUT		1	.35
T50912-C	27	LOCKWASHER		1	.04
T200073-1	28-30,4	LATCH ASSY.	1	1	47.00
T200073	28	LATCH		1	43.00
T24526	29	LATCH SPRING PLUNGER		1	1.75
T24530	30	PLUNGER PIN		1	.25
T24525	31	LATCH SPRING	12	1	.50
T200204	32	HINGE PIN	4.5	4.5	5.00
T24528	33	HINGE PIN NUT	4.5	4.5	.75
T51405-20	34	COTTER PIN	4.5	4.5	.03
T20000-SH-2	36	SAFETY HANDLE KIT (fits all AOT tongs)	3	3	3.25
T24529-TLB-MU	37	TONG LINE BLOCK, MAKE-UP (Right Hand)		A/R	31.00
T24529-TLB-BO	37	TONG LINE BLOCK, BREAK OUT (Left Hand)		A/R	31.00

**RECOMMENDED SPARE PARTS FOR 1 YEAR

